



# DVG AUTOMATION

the excellence in flow control automation

**GAS Over Oil**  
ACTUATORS

## INTRODUCTION

The DVG Automation Scotch Yoke Series incorporates several new design features to provide higher efficiency and cost effective solutions. These actuators are compact in design but all introduce a new generation of patented mechanism which minimizes wearing effect on all loaded & sliding parts, thus extending overall lifespan.

These features boost our Scotch Yoke Series for all modulating as well as heavy-duty services suitable for any quarter turn (90 deg) application.



## OPERATING RANGE

The DVG Automation Double-acting Actuators are available with individual test and guaranteed minimum output torque ranging from **350 Nm (1,500 lb-in)** to **800,000 Nm (7,080,000 lb-in)**

The Gas Over Oil standard operating pressure: **15 barg (290 psig) to 105 barg (1600 psig)**  
Standard design construction allows operating temperature from:

**-30 degC (-22 degF) to +93 degC (+199 degF)**  
Low temperature option extends operating range down to  
**-60 degC (-76 degF)**

Supply medium:  
**Sweet Gas - Hydraulic oil mineral based (standard).**  
**Special versions are available for fire-resistant, Sour Gas or water based fluids**



# KEY DESIGN FEATURES & ADVANTAGES

## Scotch Yoke:

PATENTED mechanism

## Mechanism Guide System:

PATENTED Guide Bar hard chromium plated minimizing guide block swing extending piston rod lifespan under heavy load &/or continuous modulating duty and avoiding any side load on valve stem.

Excellent surface finish and self lubricated bearings accomplish higher overall efficiency.

## External Tie Rod:

External tie-rods, zinc based chemical coating which resists 500 – 1000 hours of salt fog, maintain cylinder integrity.

## Symmetric or canted yoke:

Gas Over Oil Actuator are available with either symmetric or canted yoke design to cover as closely as possible valve resistive torque profile.

## Water ingress protection:

Totally enclosed and weather-proof actuator is engineered to meet IP66, IP67 IP67M and NEMA 4 & 4X Specifications for submerged and high pressure water deluge applications.

## Materials:

Cylinder Tube & all structural parts are manufactured in carbon steel material;

no cast/grey iron or aluminium parts are used.

All pressure containing parts are supplied with 3.1 Certificate according to EN10204.

DVG Automation guarantees, where applicable, that actuators are designed and manufactured according to PED (97/23 CE) Directive.

## Corrosion Prevention:

Cylinder tube is internally nickel-plated lined (minimum 25µm). Nickel-plating layer can be increased upon request.

External coating provides higher reliability in harsh environmental conditions as per ISO 12944 (Expected Durability) and in compliance with Norsok M-CR-501 requirements.

## Seal:

Teflon ring with internal charging O-ring and external sealing O-ring prevents sticking phenomena after prolonged "stand still" and ensures reduced hysteresis and high sensitivity.

## Bearing:

Dual piston PTFE sliding guide, yoke and guide block are mounted with steel bronze Teflon coated pushing to minimize wearing effect and obtain higher sensitivity.

## ISO Valve Mounting:

The QT Series valve interface responds to ISO 5211 dimensional requirements according to specific torque range. Different arrangements can be evaluated to meet specific need (i.e. MSS SP-101, etc.); direct mounting is feasible if available space permits.

## Labelling:

316 Stainless Steel embossed name plate ensures long lasting information preservation, thus guaranteeing lifetime traceability.

## Travel stops:

External travel stops with protective cap ensure precise angular stroke adjustment 90 -5deg/+5deg.

## Versatility & Modularity: key features for a successful design

DVG Actuator series has been designed with modular concept in mind so to have field repairable housing, power and override modules available as individual sub-assemblies to optimize spare parts inventory. Each module can be removed, serviced &/or replaced while actuator is still assembled onto the valve, without interrupting the process.

Specifically power module is designed and constructed to allow pressure testing independently from the housing.

## Safety:

Lifting point by means of DIN certified eyelet located on actuator housing.

1/2" NPT

N 1/2" NPT

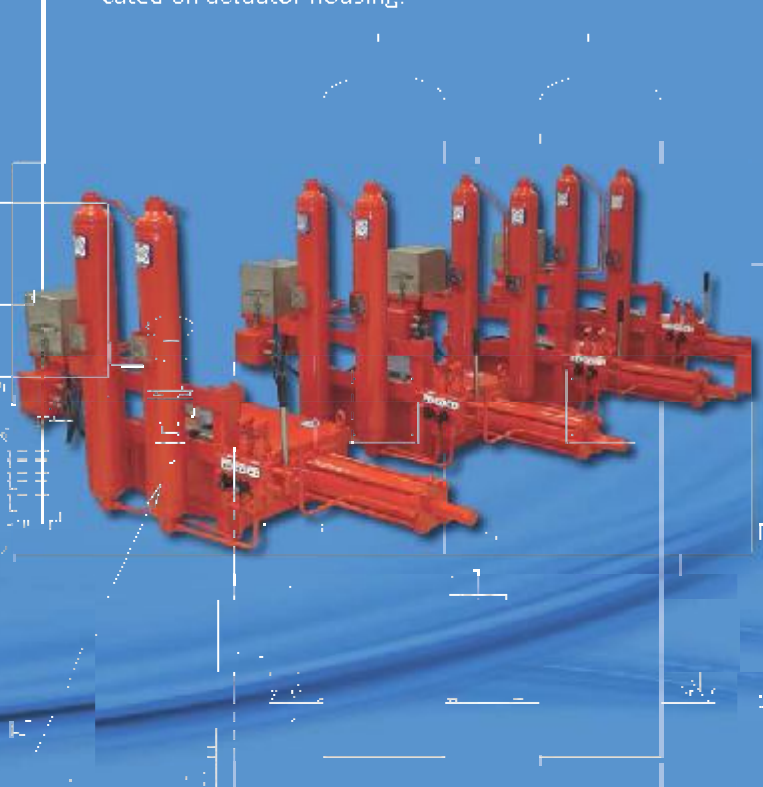

## OPTIONAL FEATURES

### Mounting pad:

Accessory mounting pad allows dual side mounting & does not require any fixing modification in case of rear side assembly.

### Manual Override:

DVG Automation provides hydraulic manual override (MH) to operate the valve in absence of power supply. Hydraulic manual override is mounted directly on actuator cylinder and includes: hand-pump, directional control valve, oil tank, relief valve.

Additional ancillary control equipment can be provided upon request.



• Hydraulic manual override



• Actuator control system

## CONTROL SYSTEM

Actuator Control Systems are integral part of any automated valve package. Our QT Series Actuators can be equipped with an extensive range of auxiliary components specifically engineered and integrated to meet the largest variety of Customers' requests.

DVG Automation has already pre-engineered different solutions to meet the most commonly required control systems. These solutions offer reduced lead time, simplified purchasing, commissioning and start-up activities. Please contact factory for any additional detail.

Standard control system:

- Local Manual Control
- Local and Remote Control
- Local and Remote c/w Pressure Pilot ESD Logic (High to Close or to Open, Low to Close or to Open)
- Local and Remote Control c/w Electric Fail Safe (to Close or to Open)

Extended Features:

- Automatic Line Break Control
- Torque Limiting Devices

Please contact factory for any additional detail.

### Position Monitor Device:

All positioning monitor devices can be assembled on top of our Gas Over Oil actuators, responding to any kind of technical requirement.



• Low temperature endurance test

# "BY" SERIES BAR YOKE

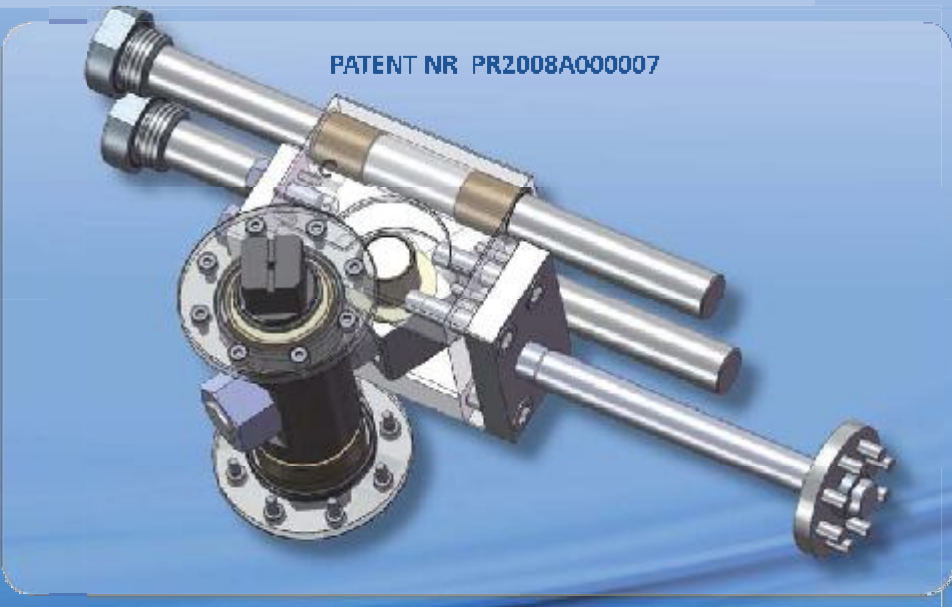
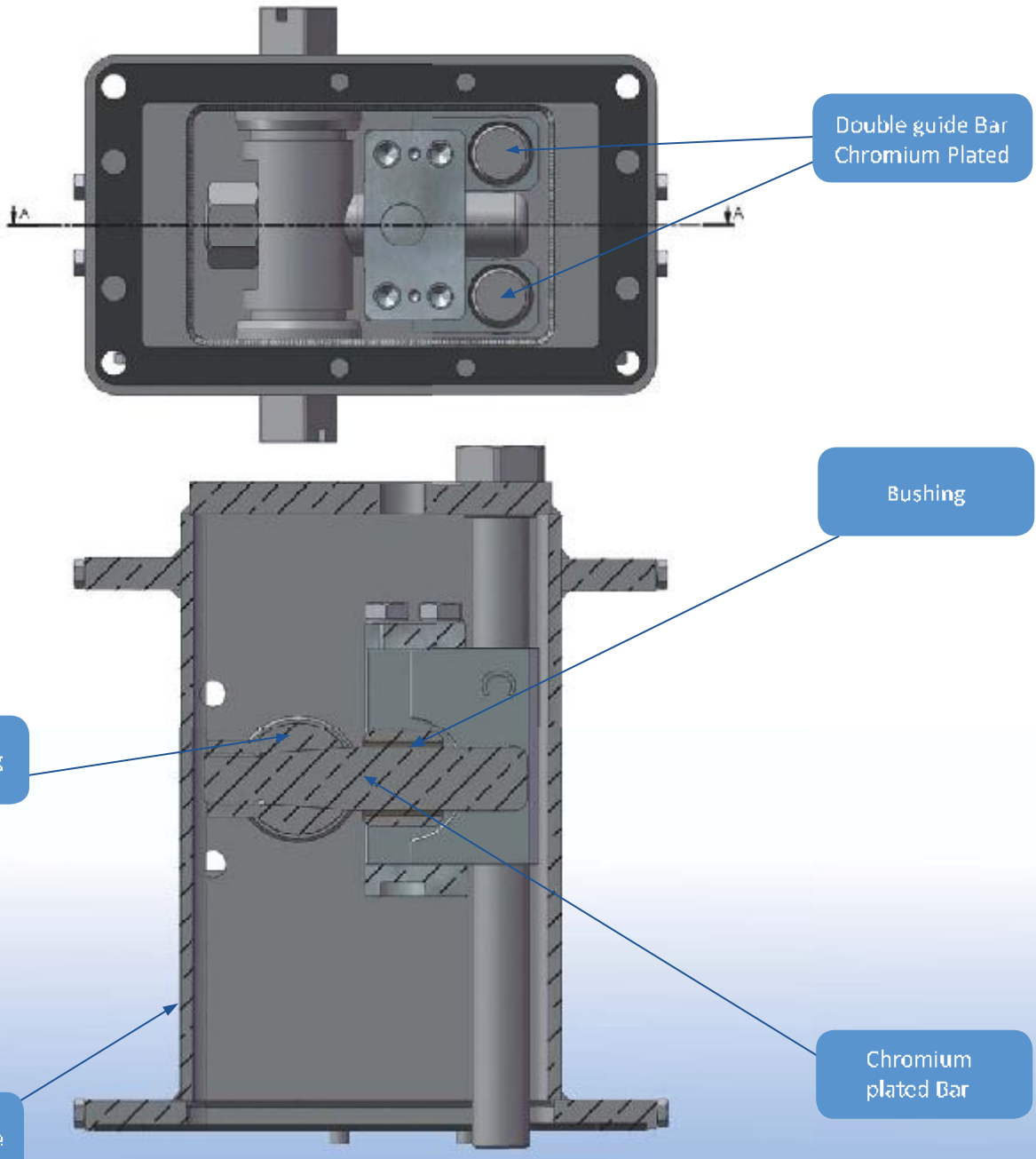

# "QT" SERIES SCOTCH YOKE

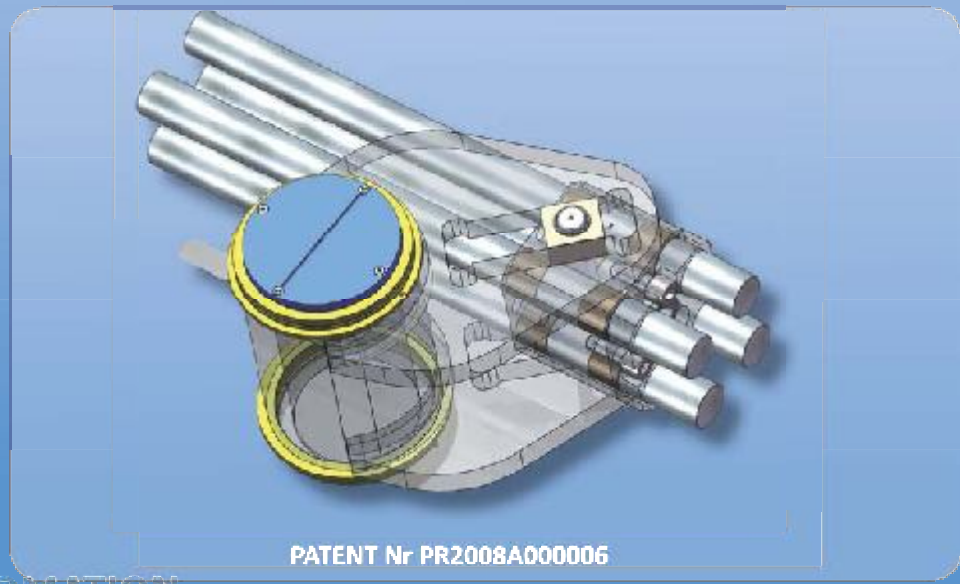
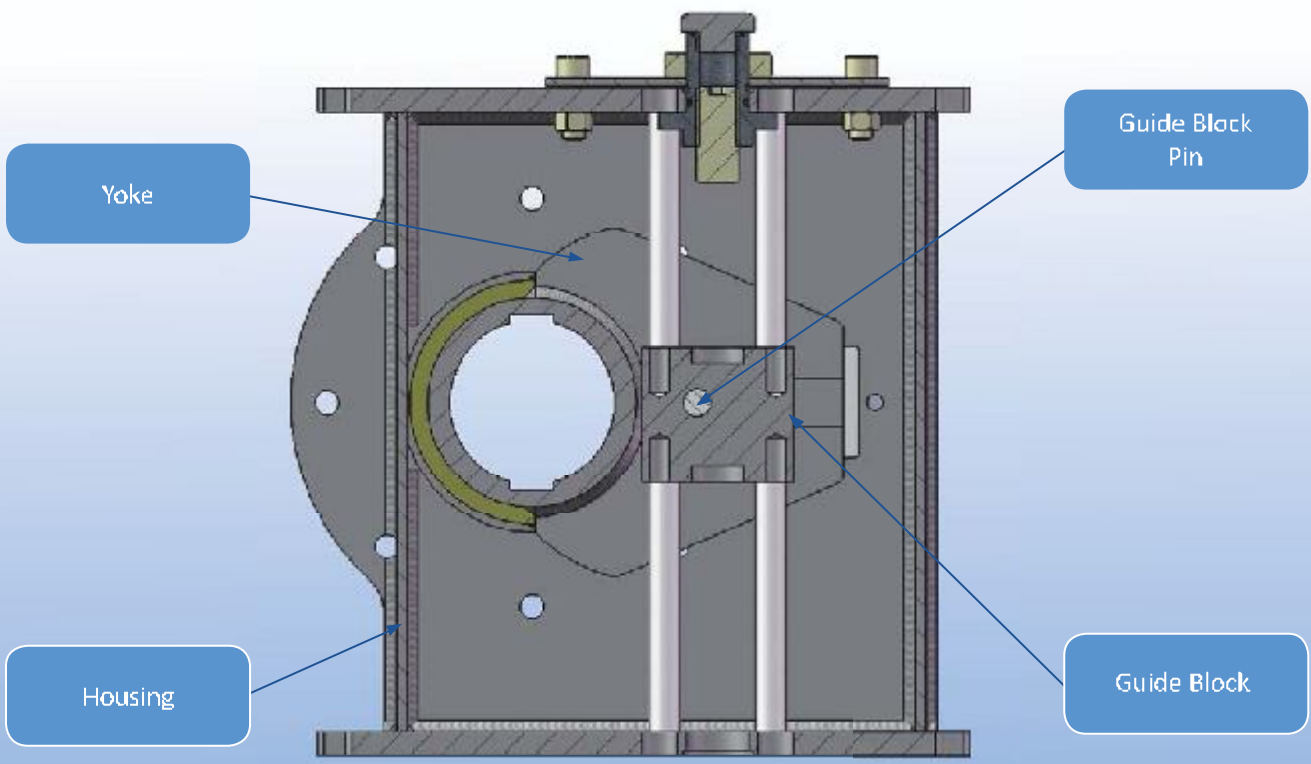
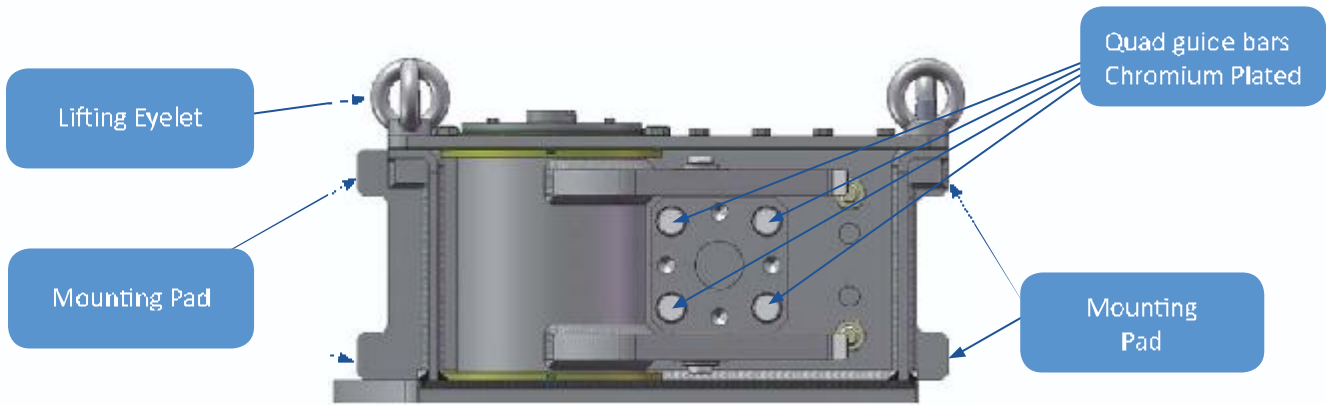

PATENT Nr PR2008A000006

# BY SERIES

## DOUBLE ACTING SECTIONAL DRAWING

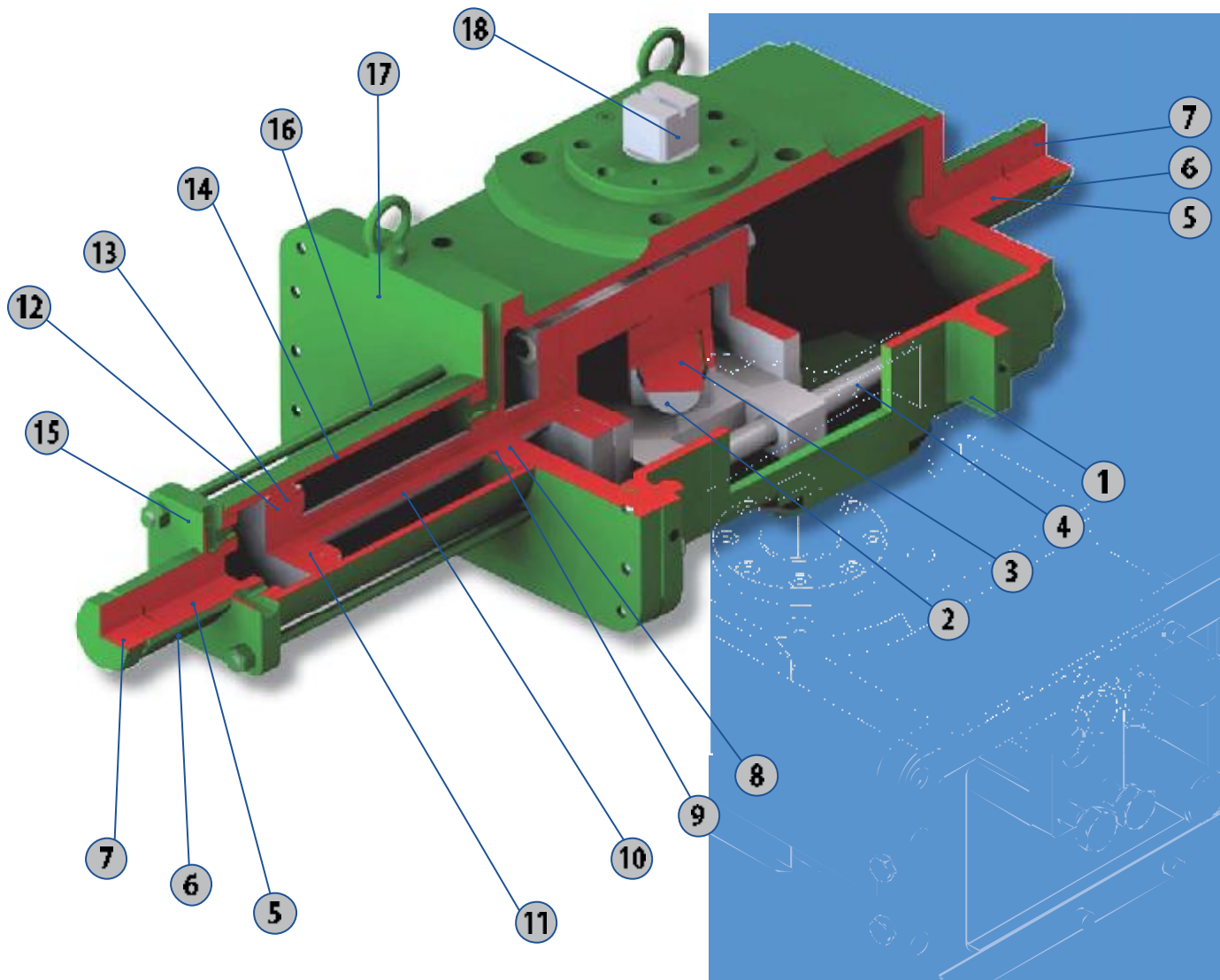

ITEM	DESCRIPTION	EN MATERIAL	ASTM MATERIAL
1	Housing	S355 J2 H EN 10210	ASTM A500 Grade C
2	Bar Yoke	42CrMo4 EN 10083	AISI (4140)
3	Yoke Bushing	Carbon steel + Bronze + PTFE	Carbon steel – Bronze + PTFE
4	Guide bar	42CrMo4 EN 10083	AISI (4140)
5	Travel stop screw	Class 45H ISO 4026	Class 45H ISO 4026
6	Stop screw protection	X5 CrNi 18 10	ASTM A276/276MTP304
7	Plug	X5 CrNi 18 10	ASTM A276/276MTP304
8	Piston rod bushing	Carbon steel + Bronze + PTFE	Carbon steel – Bronze + PTFE
9	Piston rod seal	NBR (FKM – MFQ – CR) + PTFE	NBR (FKM – MFQ – CR) + PTFE
10	Piston rod	42CrMo4 FN 10083	AISI (4140)
11	Piston	S355 .2G3 EN 10025	ASTM A570 Grade 50
12	Piston seal	NBR (FKM MFQ CR) + PTFE	NBR (FKM MFQ CR) + PTFE
13	Piston sliding guide	PTFF - Graphite	PTFF - Graphite
14	Cylinder tube	S355 K2+N EN 10297 - 10305	ASTM A500 Grade C
15	Cylinder End Flange	S355 .2G3 EN 10025	ASTM A570 Grade 50
16	Tie rod	ASTM A320 .7	ASTM A320L7
17	Cylinder Head Tange	S355 .2G3 EN 10025	ASTM A570 Grade 50
18	Stem	42CrMo4 EN 10083	AISI (4140)



# QT SERIES

## DOUBLE ACTING SECTIONAL DRAWING

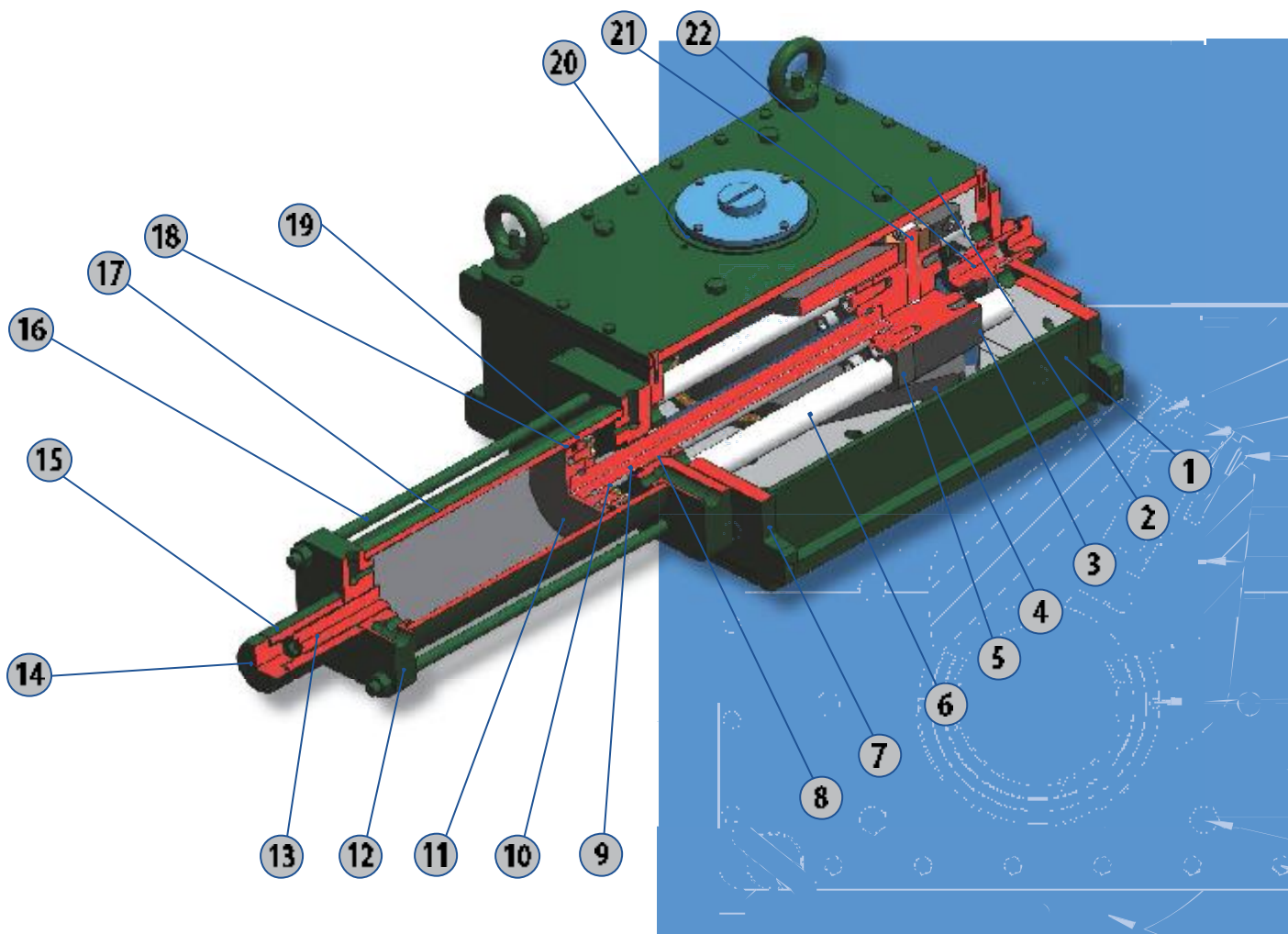

ITEM	DESCRIPTION	EN MATERIAL	ASIM MATERIAL
1	Housing	S355 J2G3 EN 10025	ASTM A570 Gr. 50
2	Cover	S355 J2G3 EN 10025	ASTM A570 Gr. 50
3	Guide block bushing	Carbon steel   Bronze   PTFE	Carbon steel   Bronze   PTFE
4	Scotch yoke	S355 J2G3 EN 10025 + E355 EN 10297	ASTM A570 Gr. 50 + ASTM A500 Gr. C
5	Guide block	S355JR EN 10025	ASTM A572 Gr 50
6	Guide bar	42CrMo4 EN10083	AISI (4140)
7	Cylinder Head flange	S355 J2G3 EN 10025	ASTM A570 Gr. 50
8	Pistor rod bushing	Carbon steel + Bronze + PTFE	Carbon steel + Bronze + PTFE
9	Piston rod seal	NBR (FKM – MFQ – CR)	NBR (FKM – MFQ – CR)
10	Piston rod	42CrMo4 EN10083	AISI (4140)
11	Piston	S355 J2G3 EN 10025	ASTM A570 Gr. 50
12	Cylinder End flange	S355 J2G3 EN 10025	ASTM A570 Gr. 50
13	Travel stop screw	Class 45H ISO 4026	Class 45H ISO 4026
14	Plug	X5 CrNi 18 10	ASTM A276/276MTP304
15	Stop screw protection	X5 CrNi 18 10	ASTM A276/276MTP304
16	Tie rod	ASTM A320L7	ASTM A320L7
17	Cylinder tube	E355K2+N EN10297 – E355+N EN10305	ASTM A580 Grade C
18	Piston seal	NBR (FKM – MFQ – CR)	NBR (FKM – MFQ – CR)
19	Piston sliding guide	PTFC+Graphite	PTFC+Graphite
20	Yoke bushing	Carbon steel + Bronze + PTFE	Carbon steel + Bronze + PTFE
21	Guide block pin	42CrMo4 EN10083	AISI (4140)
22	Travel stop screw	Class 45I ISO 4026	Class 45I ISO 4026



# ACTUATOR ASSEMBLY

10

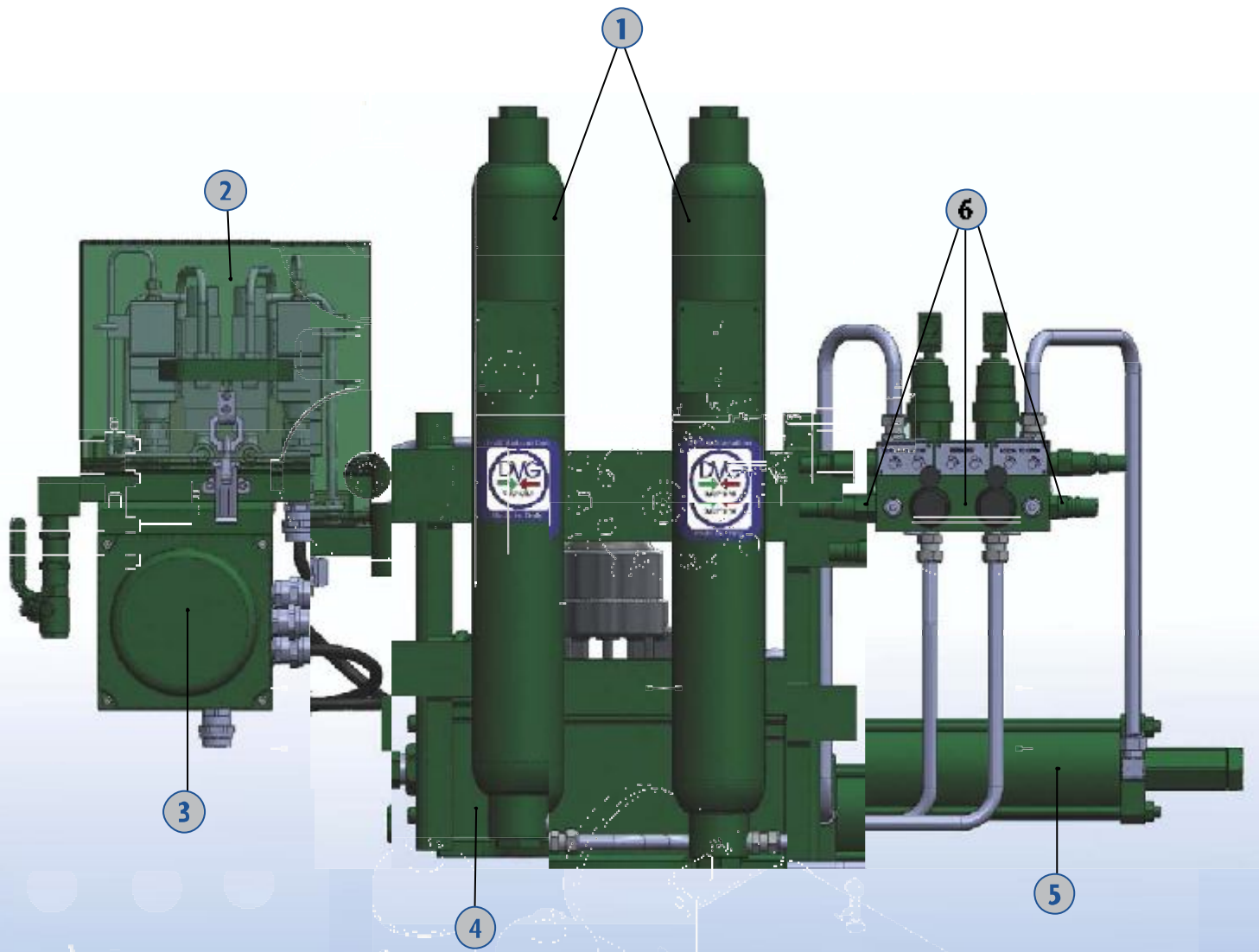

ITEM	DESCRIPTION
1	Gas Over Oil tanks
2	Control Group
3	Junction Box
4	Scotch Yoke Mechanism
5	Hydraulic Cylinder
6	Hydraulic Group- Manual pumps and flow regulators

# GAS OVER OIL



# GAS OVER OIL LOCAL AND REMOTE CONTROL

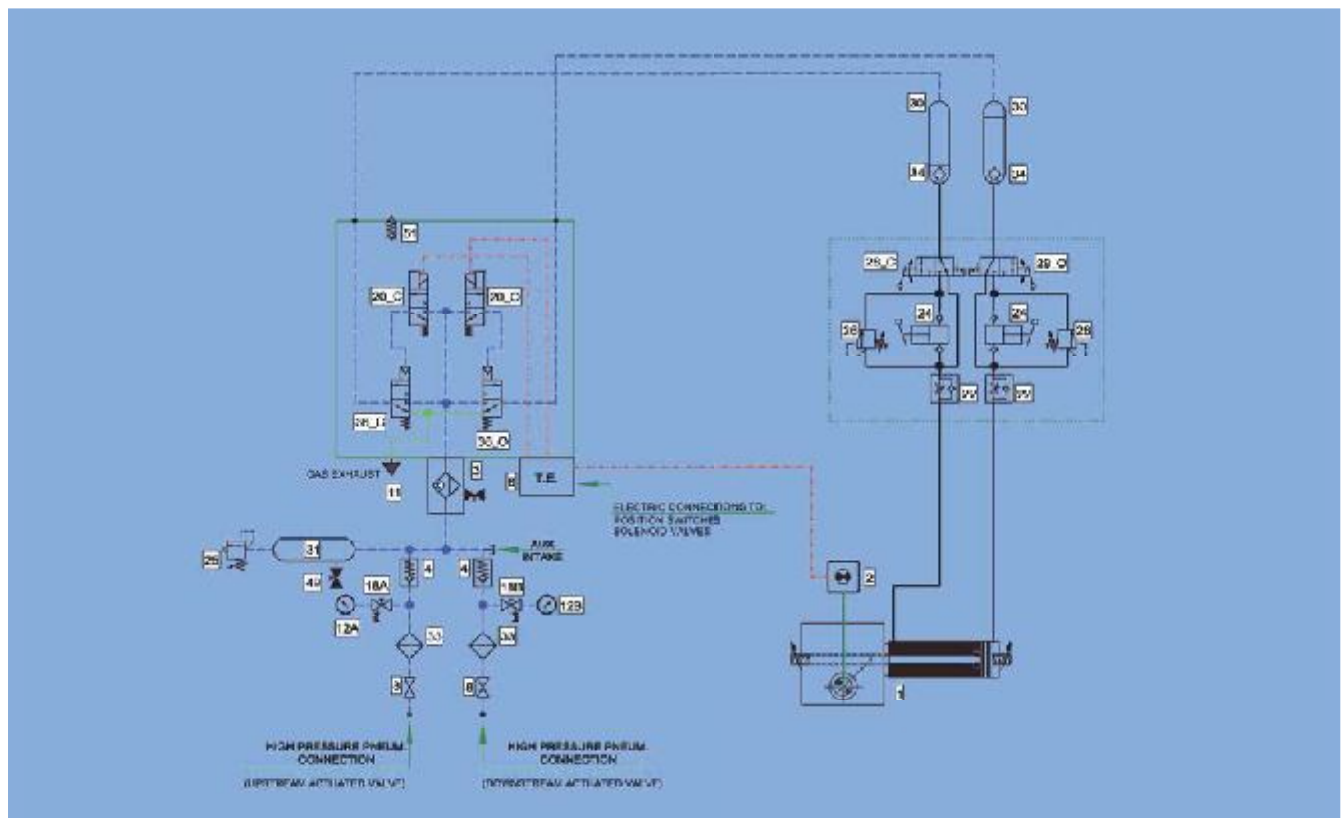

Item	Description
1	Gas Over Oil double acting actuator
2	Limit Switch Box
3	Condenser filter with drain valve
4	Check Valve
6	Junction Box
8	Isolating Valve
11	Exhaust
12	Pressure Gauge
12ABB	Pressure Gauge (NOT INCLUDED IN DVG SCOPE)
12AB	Gauge Isolator Valve (NOT INCLUDED IN DVG SCOPE)
20_O/C	3/2 N.C. solenoid valve with manual actuation
22	Uni-directional flow control valve - adjustable setting
24	Hydraulic Hand Pump
25	Relief Valve (Pneumatic)
26	Relief Valve (Hydraulic)
28_O/C	3/2 universal directional valve hand rotary control
30	Gas-Over-Oil bottle
31	Back-up volume tank
33	Mechanical Filter
34	Hydraulic filter
36_O/C	3/2 N.C. Pneumatic pressure pilot spring return
49	Drain Valve
51	Enclosure Vent/Breather

### MANUAL LOCAL OPERATION

ACTUATE SOLENOID VALVE MANUAL OVERRIDE (20\_O) TO OPEN OR (20\_C) TO CLOSE THE OPERATOR THROUGHOUT THE ENTIRE VALVE STROKE. OVERRIDE SHALL BE RELEASED AT THE END OF THE VALVE STROKE

### REMOTE OPERATION

ENERGIZE SOLENOID VALVE COIL (20\_O) TO OPEN OR (20\_C) TO CLOSE THE OPERATOR THROUGHOUT THE ENTIRE VALVE STROKE. COIL SHALL BE DE-ENERGIZED AT THE END OF THE VALVE STROKE

### MANUAL OPERATION BY HANDPUMP

SELECT OPEN OR CLOSE OPERATION BY RELEVANT DIRECTIONAL VALVE (28\_O) TO OPEN (28\_C) TO CLOSE AND ACTIVATE PROPER HANDPUMP (24) TO OPEN TO CLOSE. IMPORTANT NOTE BOTH DIRECTIONAL VALVES SHALL BE POSITIONED IN REMOTE POSITION (HANDLES IN VERTICAL POSITION) TO ALLOW OPERATION WITH POWER GAS

NOTES: wiring diagram is drafted in the following conditions:

- Main Valve Closed
- No pneumatic supply
- No electric power supply

### CONNECTIONS:

- Hydraulic connection
- High Pressure pneumatic connection
- Pneumatic exhaust connection
- Electric connection

# GAS OVER OIL

## LOCAL AND REMOTE CONTROL WITH TORQUE LIMITING DEVICE

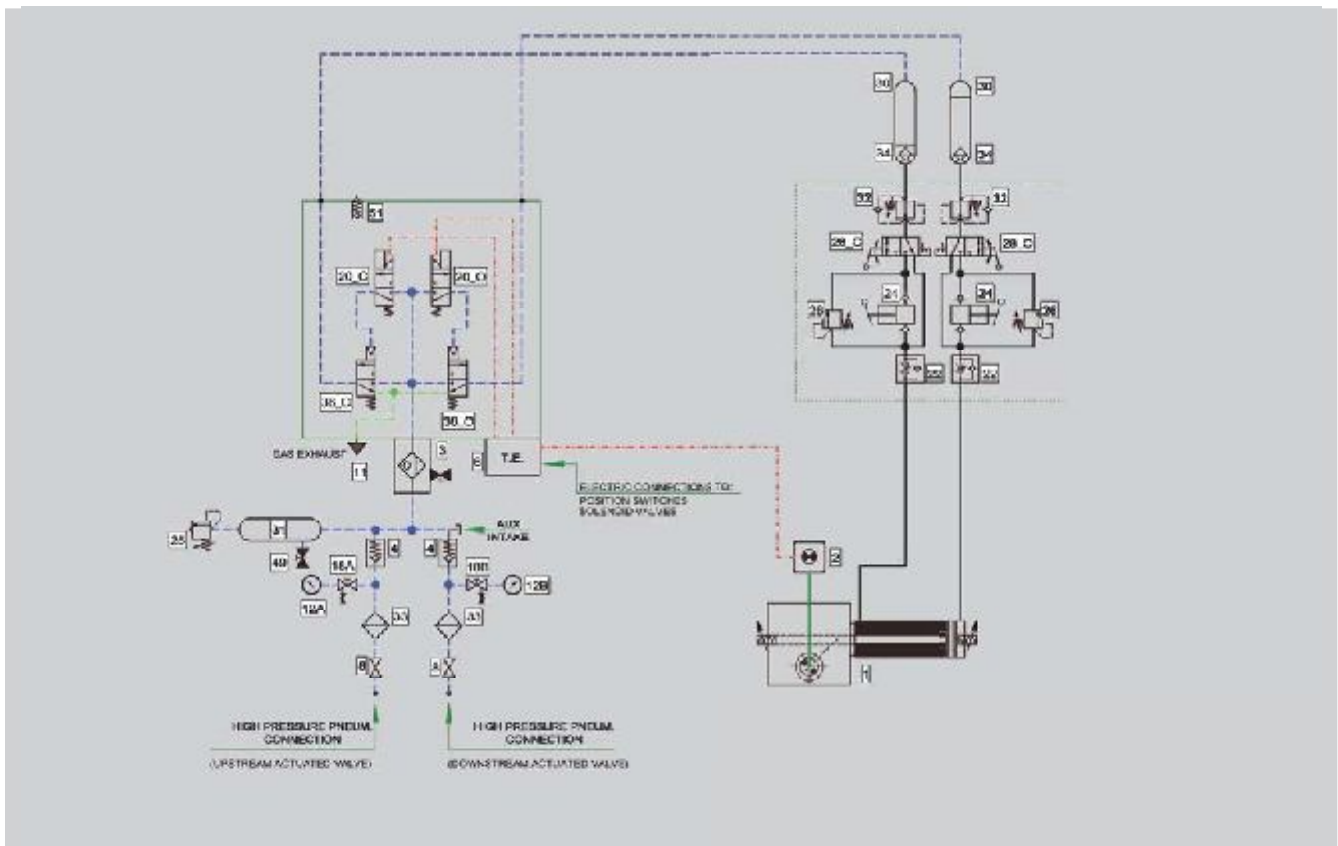

Item	Description
1	Gas-Over-Oil double acting actuator
2	Limit Switch Flow
3	Coalescent filter with drain valve
4	Check valve
6	Junction Box
8	Isolating Valve
11	Exhaust
12	Pressure Gauge
12A&B	Pressure Gauge
18A&B	Gauge Isolator Valve
20_O/C	3/2 N.C. solenoid valve with manual actuation
22	Uni-directional flow control valve - adjustable setting
24	Hydraulic Hand Pump
25	Relief Valve (Pneumatic)
26	Relief Valve (Hydraulic)
26_O/C	3/2 universal directional valve hand rotary control
30	Gas-Over-Oil bottle
31	Back-up volume tank
32	Torque Limiting Device
33	Mechanical Filter
34	Hydraulic filter
36_O/C	3/2 N.C. Pneumatic pressure pilot spring return
49	Drain Valve
51	Enclosure Vent/Breather

**NOTES:** wiring diagram is drafted in the following conditions:

- Main Valve Closed
- No pneumatic supply
- No electric power supply

**CONNECTIONS:**

- Hydraulic connection
- High Pressure pneumatic connection
- Pneumatic exhaust connection
- Electric connection

### MANUAL LOCAL OPERATION

ACTUATE SOLENOID VALVE MANUAL OVERRIDE (20\_C) TO OPEN OR (20\_O) TO CLOSE THE OPERATOR THROUGHOUT THE ENTIRE VALVE STROKE. OVERRIDE SHALL BE RELEASED AT THE END OF THE VALVE STROKE.

### REMOTE OPERATION

ENERGIZE SOLENOID VALVE COIL (20\_O) TO OPEN OR (20\_C) TO CLOSE THE OPERATOR THROUGHOUT THE ENTIRE VALVE STROKE. COIL SHALL BE DE-ENERGIZED AT THE END OF THE VALVE STROKE.

### MANUAL OPERATION BY HANDPUMP

SELECT OPEN OR CLOSE OPERATION BY RELEVANT DIRECTIONAL VALVE (26\_O) TO OPEN (26\_C) TO CLOSE AND ACTUATE PROPER HANDPUMP (24) TO OPEN TO CLOSE. IMPORTANT NOTE BOTH DIRECTIONAL VALVES SHALL BE POSITIONED IN REMOTE POSITION (HANDLES IN VERTICAL POSITION) TO ALLOW OPERATION WITH POWER GAS.

### TORQUE LIMITING DEVICE OPERATION

TORQUE LIMITING DEVICES (32) ACT AS HYDRAULIC PRESSURE REGULATOR LIMITING MAXIMUM DEVELOPED TORQUE DURING OPERATOR OPERATION. Torque Limiting Device SETTING IS FACTORY ADJUSTED. TLD OPERATION DOES NOT RELEASE GAS INTO THE ATMOSPHERE.

# GAS OVER OIL

## LOCAL AND REMOTE CONTROL WITH LOW PRESSURE ESD + OPENING PREVENTION + TORQUE LIMITING DEVICE

14

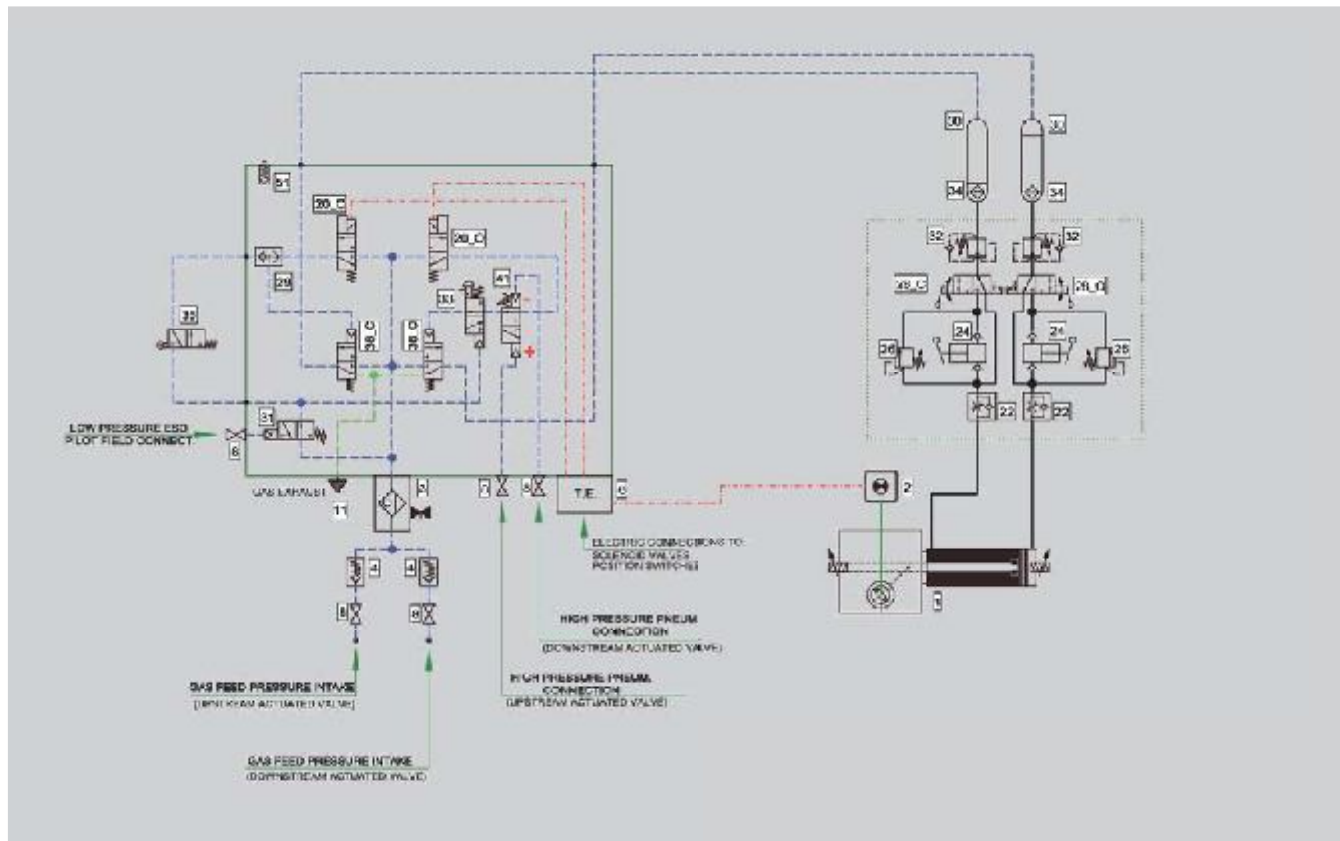

Item	Legend Description
1	Gas-Over-Oil double acting actuator
2	Limit Switch Box
3	Coalescent filter with drain valve
4	Check Valve
6	Junction Box
8	Isolating Valve
11	Exhaust
20_0/C	3/2 N.C. solenoid valve with manual actuation
22	Uni-directional flow control valve - adjustable setting
24	Hydraulic Hand Pump
26	Relief Valve (Hydraulic)
28_0/C	3/2 internal directional valve hand return control
29	Shuttle valve
30	Gas-Over-Oil bottle
31	3/2 N.C. Pneumatic pressure switch adjustable setting
32	Torque Limiting Device
33	3/2 N.C. Pneumatic pressure pilot - manual reset
34	Hydraulic filter
35	3/2 Roller pilot spring return
36_0/C	3/2 N.C. Pneumatic pressure pilot spring return
41	3/2 Differential Pressure Pilot adjustable setting
61	Enduro Vant Brusher

NOTES: wiring diagram is drafted in the following conditions:

- Main Valve Closed
- No pneumatic supply
- No electric power supply
- Roller pilot spring return (Item 35) ACTUATED
- LOW PRESSURE ESD pilot (Item 31) TRIPPED
- Differential pressure pilot (Item 41) NOT TRIPPED

CONNECTIONS:

- Hydraulic connection
- High Pressure pneumatic connection
- Pneumatic exhaust connection
- Electric connection

### MANUAL LOCAL OPERATION

ACTUATE SOLENOID VALVE MANUAL OVERRIDE (20\_0) TO OPEN OR (20\_C) TO CLOSE THE OPERATOR THROUGHOUT THE ENTIRE VALVE STROKE. OVERRIDE SHALL BE RELEASED AT THE END OF THE VALVE STROKE

### REMOTE OPERATION

ENERGIZE SOLENOID VALVE COIL (20\_0) TO OPEN OR (20\_C) TO CLOSE THE OPERATOR THROUGHOUT THE ENTIRE VALVE STROKE. COIL SHALL BE DE-ENERGIZED AT THE END OF THE VALVE STROKE

### MANUAL OPERATION BY HANDPUMP

SELECT OPEN OR CLOSE OPERATION BY RELEVANT DIRECTIONAL VALVE (28\_0) TO OPEN (28\_C) TO CLOSE AND ACTUATE PROPER HANDPUMP (24) TO OPEN OR TO CLOSE. IMPORTANT NOTE BOTH DIRECTIONAL VALVES SHALL BE POSITIONED IN REMOTE POSITION (HANDLES IN VERTICAL POSITION) TO ALLOW OPERATION WITH POWER GAS

OPENING ACTION PREVENTION FOR HIGH DIFFERENTIAL PRESSURE ACROSS MAIN VALVE THE DIFFERENTIAL PRESSURE PILOT (41) SENSING PORTS ARE CONNECTED UPSTREAM & DOWNSTREAM MAIN VALVE TO THE PIPELINE. WHEN DIFFERENTIAL PRESSURE EXCEEDS PRESET THRESHOLD OPENING OPERATION IS INHIBITED

### EMERGENCY SHUTDOWN OPERATION IN CASE OF PIPELINE LOW PRESSURE

WHEN PIPELINE PRESSURE DROPS BELOW PNEUMATIC PRESSURE SWITCH (31) SETTINGS, IT TRIPS AND DRIVES THE PNEUMATIC PILOT (33) TO INHIBIT OPEN OPERATION AND PRESSURE PILOT (36\_C) TO PERFORM OPERATOR CLOSING OPERATION. THE END OF THE CLOSING STROKE ACTUATES ROLLER PILOT (35) WHICH DE-ACTIVATES (36\_C) PRESSURE PILOT. POWER GAS IS EXHAUSTED FROM THE GAS-OVER-OIL BOTTLE (30). NORMAL OPERATION IS RESTORED BY PNEUMATIC PILOT (33) LOCAL MANUAL RESET. THE ESD SENSING PORT MUST BE CONNECTED UPSTREAM THE VALVE (ACCORDING TO FLOW DIRECTION) AND PRESSURE INTAKE MUST BE SEPARATE FROM THE GAS FEED PRESSURE INTAKES

### TORQUE LIMITING DEVICE OPERATION

TORQUE LIMITING DEVICES (32) ACT AS HYDRAULIC PRESSURE REGULATOR LIMITING MAXIMUM DEVELOPED TORQUE DURING OPERATOR OPERATION. (Torque Limiting Device) SETTING IS FACTORY ADJUSTED. TLD OPERATION DOES NOT RELEASE GAS INTO THE ATMOSPHERE.



# GAS OVER OIL LOCAL AND REMOTE CONTROL WITH LINE BREAK DEVICE + TORQUE LIMITING DEVICE

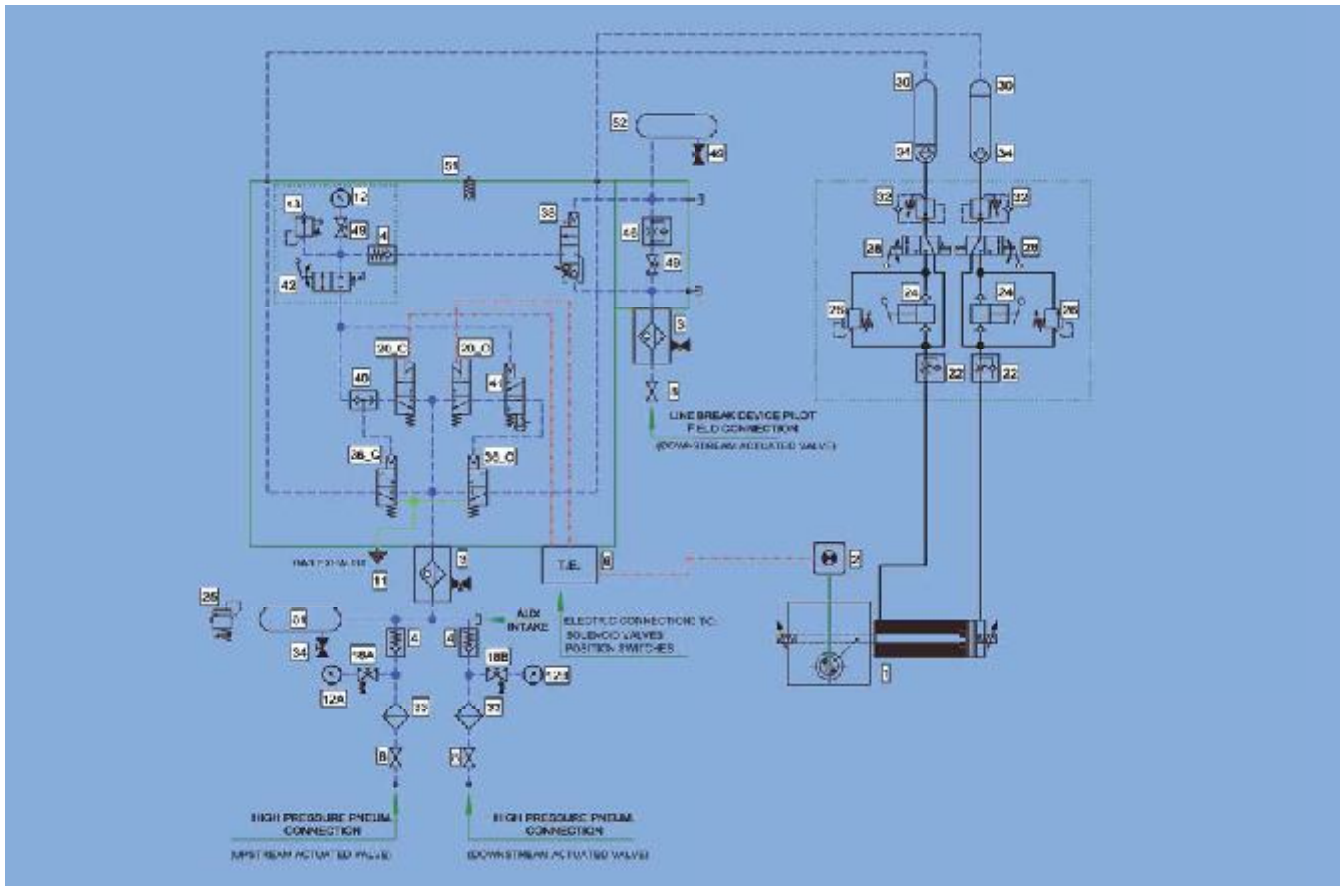

Legend	
Item	Description
1	Gas-Over-Oil double acting actuator
2	Limit Switch Box
3	Coalescent filter with drain valve
4	Check Valve
5	Junction Box
8	Isolating Valve
11	Exhaust
12	Pressure Gauge
12A&B	Pressure Gauge
16A&B	Gauge excluder valve
20_O&C	3/2 N.C. solenoid valve with manual actuation
22	Uni-directional flow control valve - adjustable setting
24	Hydraulic Hand Pump
25	Relief Valve (Pneumatic)
29	Relief Valve (Hydraulic)
28	3/2 universal directional valve hand rotary control
30	Gas-Over-Oil bottle
31	Back-up volume tank
32	Torque Limiting Device
33	Mechanical Filter
34	Hydraulic filter
38_O&C	3/2 N.C. Pneumatic pressure pilot spring return
38	2/2 N.C. Differential Pressure Pilot adjustable setting
40	Shuttle valve
41	3/2 N.O. Pneumatic pressure pilot - manual reset
42	2 port-2 position control valve hand rotary control
43	Low Pressure Bleed Valve
46	Uni-directional Calibrated Orifice
49	Needle/Drain Valve
51	Enclosure Vent/Breather
52	Line Break Reference Tank Volume

#### MANUAL LOCAL OPERATION

ACTUATE SOLENOID VALVE MANUAL OVERRIDE (20\_O) TO OPEN OR (20\_C) TO CLOSE THE OPERATOR THROUGHOUT THE ENTIRE VALVE STROKE. OVERRIDE SHALL BE RELEASED AT THE END OF THE VALVE STROKE.

#### REMOTE OPERATION

ENERGIZE SOLENOID VALVE COIL (20\_O) TO OPEN OR (20\_C) TO CLOSE THE OPERATOR THROUGHOUT THE ENTIRE VALVE STROKE. COIL SHALL BE DE-ENERGIZED AT THE END OF THE VALVE STROKE.

#### REMOTE OPERATION

A RATE OF PRESSURE DROP INTO THE PIPELINE DETERMINES A DIFFERENTIAL PRESSURE ACROSS THE DIFFERENTIAL PRESSURE PILOT (38) DIAGRAM. WHEN DIFFERENTIAL PRESSURE EXCEEDS PRESET THRESHOLD THE PILOT (38) TRIPS AND DRIVES THE PRESSURE PILOT (41) TO INHIBIT OPEN OPERATION AND THE PRESSURE PILOT (38\_O) TO CLOSE THE ACTUATOR. AFTER RATE OF PRESSURE DROP TRIP LOCAL MANUAL RESET OF THE PRESSURE PILOT (41) IS REQUIRED TO RESTORE NORMAL OPERATION. THE LINE BREAK SENSING PORT MUST BE CONNECTED DOWNSTREAM THE MAIN VALVE (ACCORDING TO FLOW DIRECTION) AND PRESSURE INTAKE MUST BE SEPARATE FROM THE GAS FEED PRESSURE INTAKES.

#### TORQUE LIMITING DEVICE OPERATION

TORQUE LIMITING DEVICES (52) ACT AS HYDRAULIC PRESSURE REGULATOR LIMITING MAXIMUM DEVELOPED TORQUE DURING OPERATOR OPERATION. T(orque) L(imiting) D(evice) SETTING IS FACTORY ADJUSTED. TLD OPERATION DOES NOT RELEASE GAS INTO THE ATMOSPHERE.

NOTES: wiring diagram is drafted in the following conditions:

- Main Valve Closed
- No pneumatic supply
- No electric power supply

#### CONNECTIONS:

- Hydraulic connection
- High Pressure pneumatic connection
- Pneumatic exhaust connection
- Electric connection

# GAS OVER OIL TYPICAL CONTROL SYSTEM

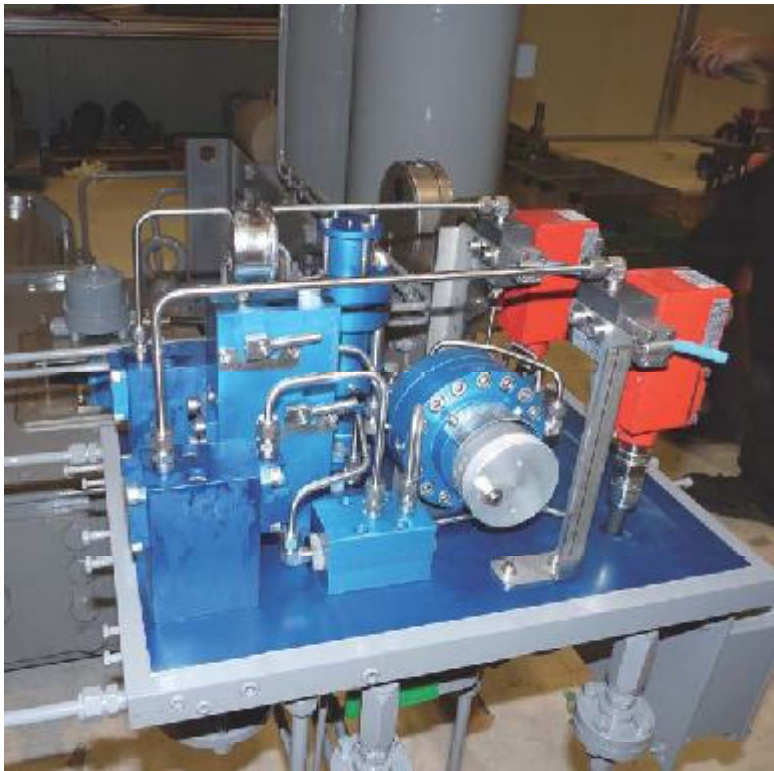

• Local Remote + Line Break



♦ Local Remote + ESD + Opening Prevention



• Local Remote



♦ Local Remote Electric ESD





# BY OVERALL DIMENSIONS

18

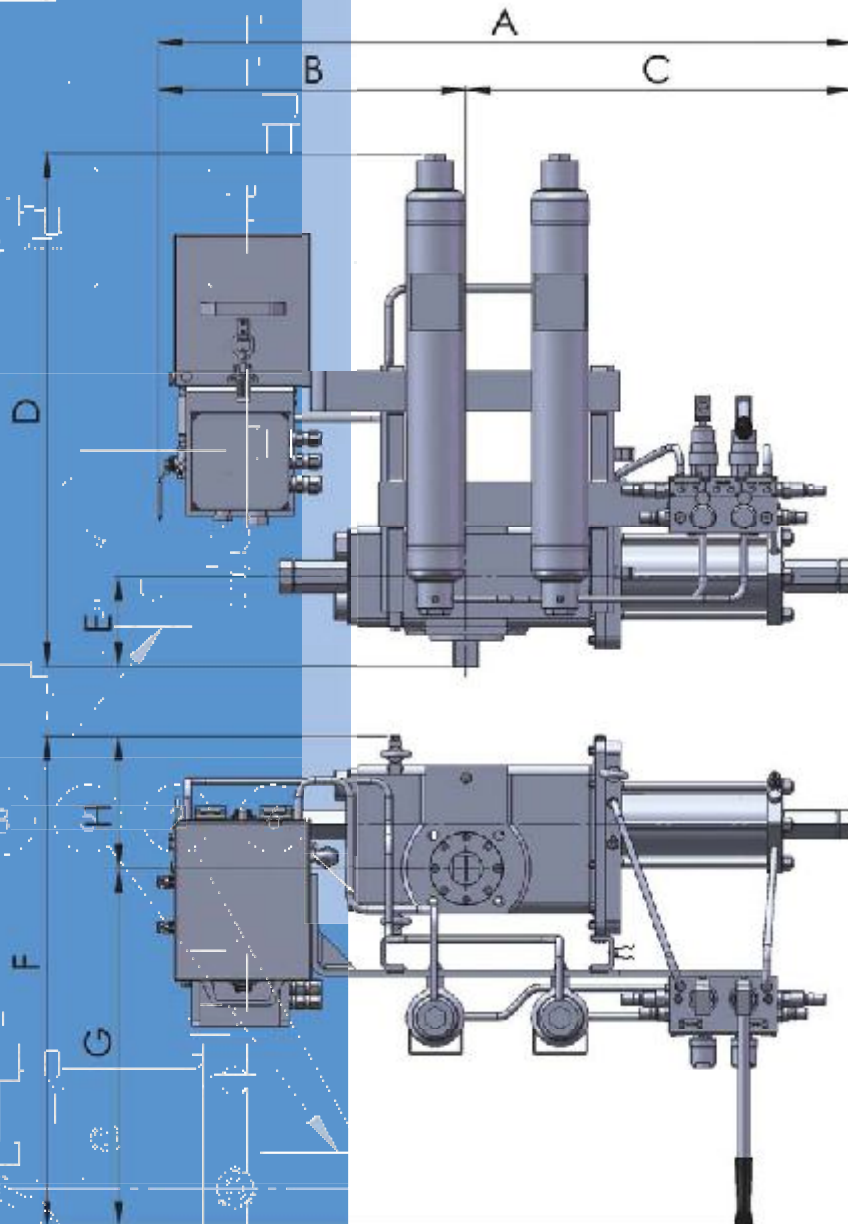

Model Size	A	B	C	D	E	F	G	H	Weight (Kg)
3YO 05S/C 40	827	472	355	780	69	740	624	116	163
3YO 05S/C 50	827	472	355	780	69	740	624	116	163
BYO-20S/C-45	1041	516	525	876	105	805	632	173	182
BYO-20S/C-55	1041	516	525	876	105	805	632	173	182
BYO-20S/C-65	1041	516	525	876	105	805	632	173	182
BYO 50S/C 55	1178	549	629	904	159	865	631	234	202
BYO-50S/C-75	1228	549	679	904	159	865	631	234	210
BYO-50S/C-95	1228	549	679	904	159	865	631	234	210

# BY HOUSING

## MOUNTING HOLES AND INTERFACE

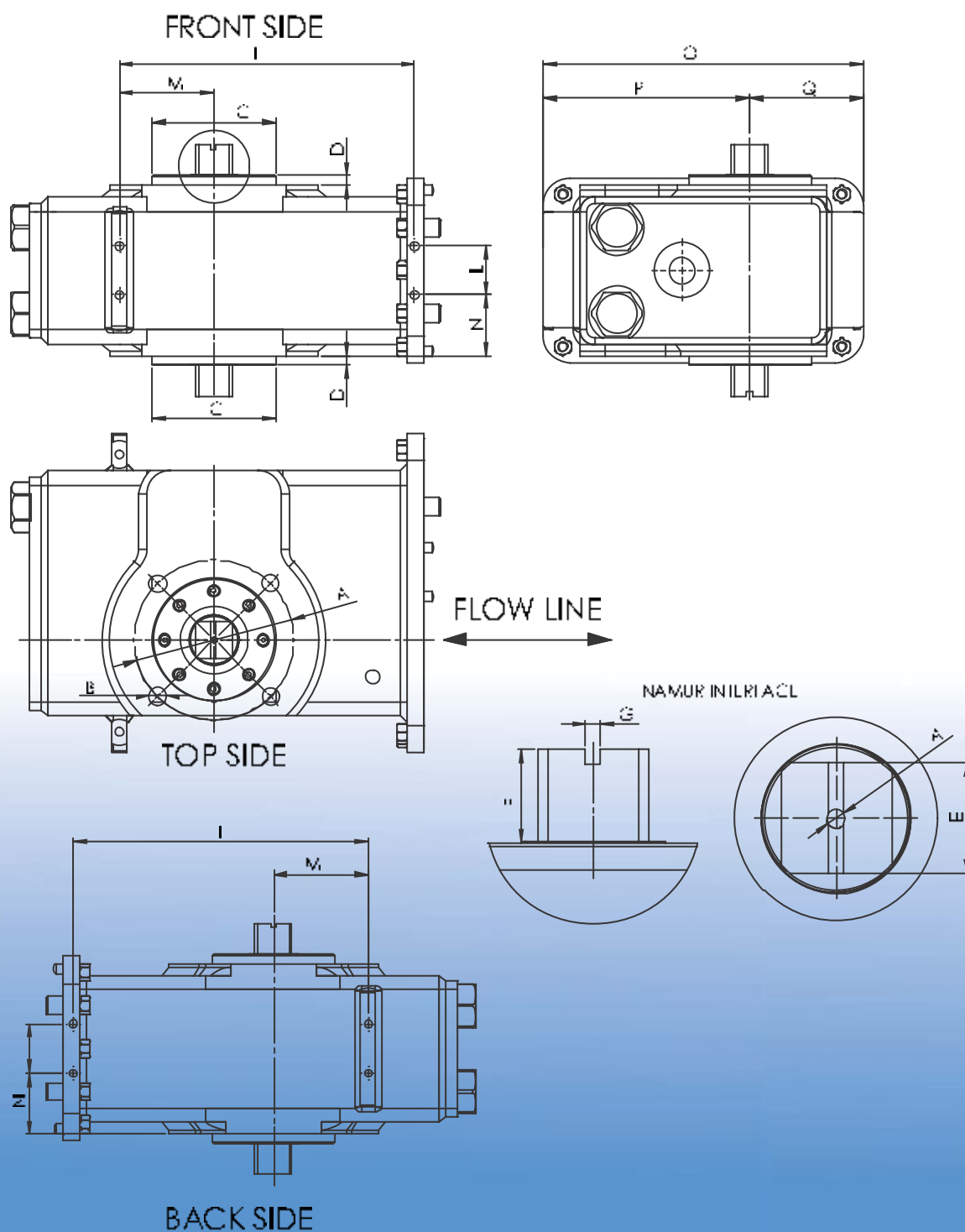

model size	A	B	C	D	E	F	G	H	I	L	M	N	O	P	Q
5	76	N4 M10	55	6.5	18	16	4	M6	170	24	64.5	33	180	113	67
20	130	N4 M16	100	7.5	30	25	4	M6	240	40	77	50.5	260	168	92
50	165	N4 M20	129	10	45	45	4	M6	360	85	124.5	60.5	345	228	117



# QT OVERALL DIMENSIONS

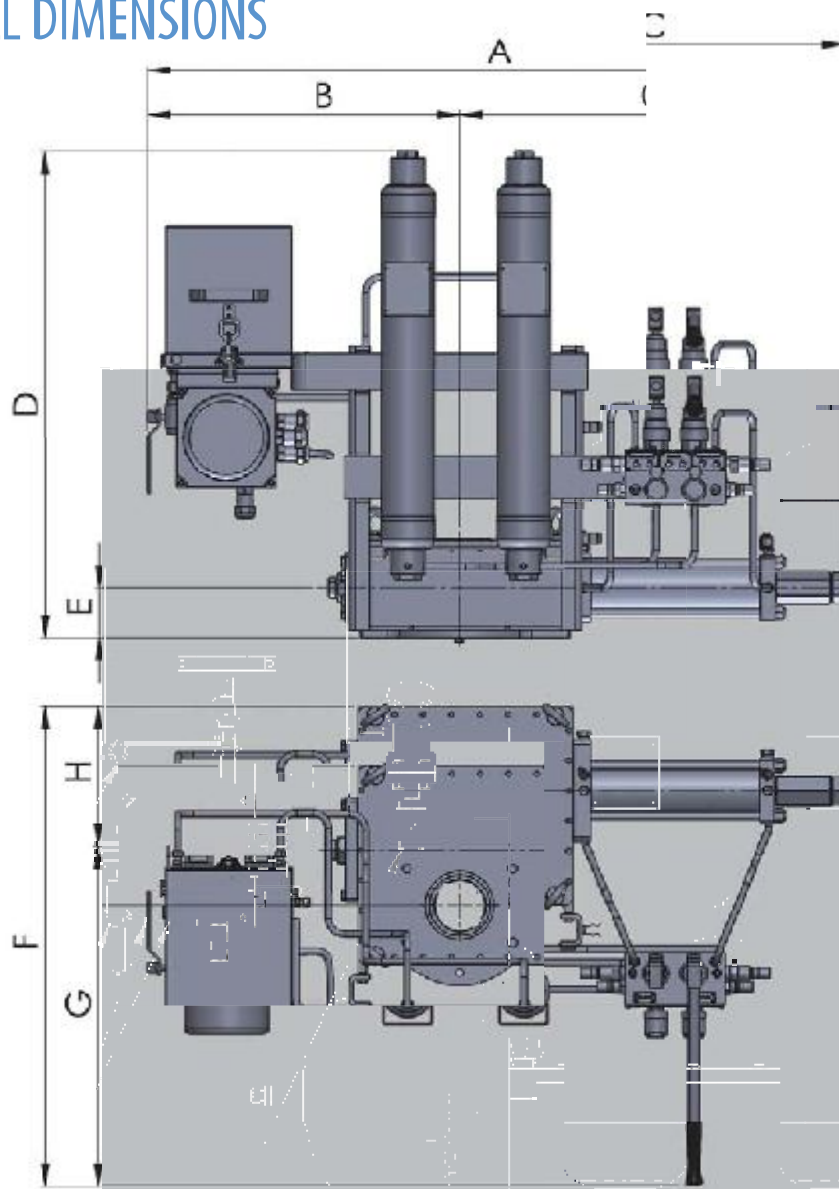

Model Size	A	B	C	D	E	F	G	H	Weight (Kg)
QTO-010S/C-95	1321	562	759	924	96	910	615	265	199
QTO-010S/C-120	1321	562	759	924	96	910	645	265	199
QTO-016S/C-95	1550	681	869	980	111	986	665	321	295
QTO-016S/C-120	1550	681	869	980	111	986	665	321	295
QTO-016S/C-135	1555	681	874	980	111	986	665	321	300
QTO-030S/C-120	1885	763	1122	1180	130	1190	760	430	510
QTO-030S/C-135	1887	763	1124	1180	130	1190	760	430	512
QTO-030S/C-150	1888	763	1125	1180	130	1190	760	430	514
QTO-060S/C-150	2162	813	1349	1095	163	1352	811	541	818
QTO-060S/C-175	2172	813	1359	1095	163	1352	811	541	820
QTO-060S/C-200	2172	813	1359	1095	163	1352	811	541	820
QTO-120S/C-200	2431	891	1540	1657	205	1447	822	625	1247
QTO-120S/C-235	2462	891	1571	1657	205	1447	822	625	1262
QTO-120S/C-280	2471	891	1580	1657	205	1447	822	625	1268
QTO-120S/C-300	2476	891	1585	1657	205	1447	822	625	1275
QTO-120S/C-335	2479	891	1588	1657	205	1447	822	625	1279
QTO-180S/C-235	2614	916	1698	2127	230	1577	892	685	1655
QTO-180S/C-280	2621	916	1705	2127	230	1577	892	685	1658
QTO-180S/C-300	2626	916	1710	2127	230	1577	892	685	1670
QTO-180S/C-335	2626	916	1710	2127	230	1577	892	685	1670
QTO-180S/C-385	2631	916	1715	2127	230	1577	892	685	1674

# QT SERIES HOUSING MOUNTING HOLES AND INTERFACE

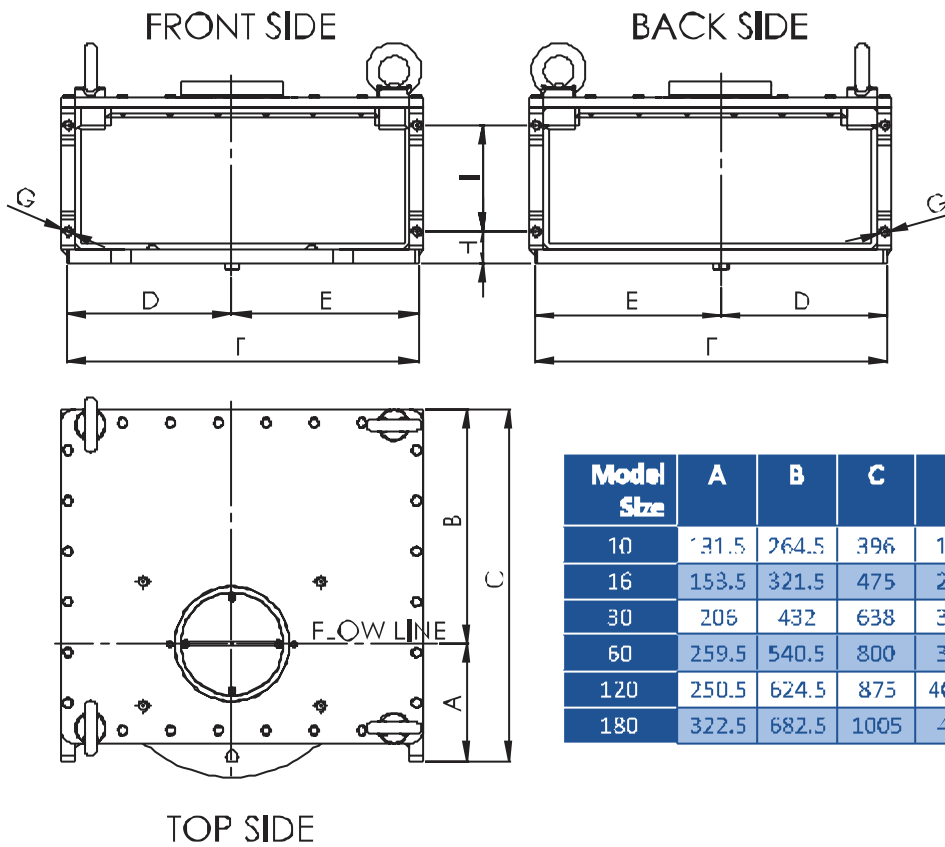

Model Size	A	B	C	D	E	F	G	H	I
10	131.5	264.5	396	185	208	393	N.4 M10	36	120
16	153.5	321.5	475	221	249	470	N.4 M10	36	150
30	206	432	638	310	350	660	N.4 M16	44.5	170
60	259.5	540.5	800	358	418	776	N.4 M20	62.5	205
120	250.5	624.5	875	406.5	476.5	883	N.4 M24	62	290
180	322.5	682.5	1005	446	523	969	N.4 M24	74	290

## QT SERIES COVER AND YOKE MOUNTING HOLES

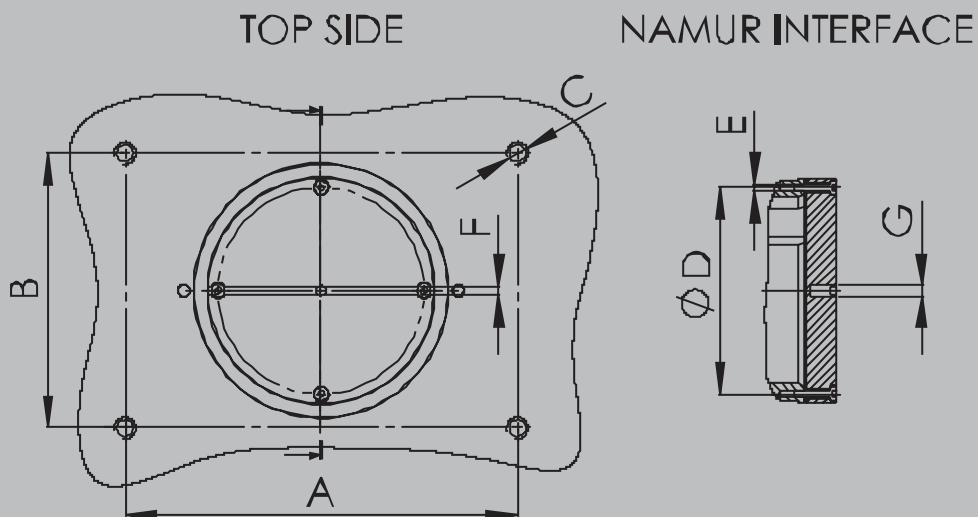

Model Size	A	B	C	D	E	F	G
10	200	140	N.4 M10	105	N.4 M4	4	M6
16	230	170	N.4 M10	132.5	N.4 M5	4	M6
30	240	180	N.4 M10	174	N.4 M6	4	M6
60	300	270	N.4 M12	216	N.4 M6	4	M6
120	300	270	N.4 M12	240	N.4 M6	4	M6
180	310	290	N.4 M12	240	N.4 M6	4	M6

# QT SERIES COUPLING DIMENSIONS FOR MODELS QTO 10-60

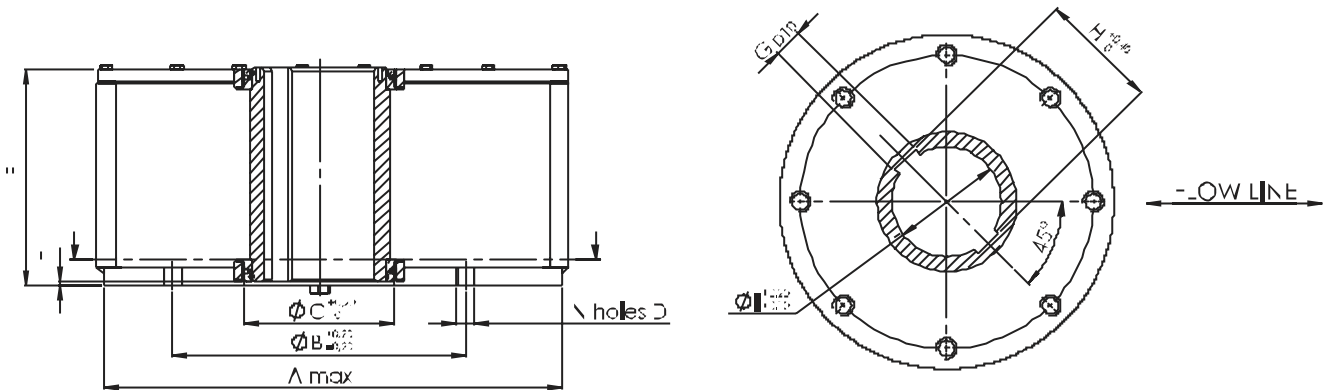

Model Size	A	B	C	D	E	F	G	H	I
10	300	254	130	N.8 M16	3	186	25	102.6	95
16	350	298	165	N.8 M20	3	215	32	128.8	120
30	415	356	210	N.8 M30	3	252	32	174.8	160
60	520	406	260	N.8 M36	3	312	32	209.8	195

# QT SERIES COUPLING DIMENSIONS FOR MODELS QTO 120-180

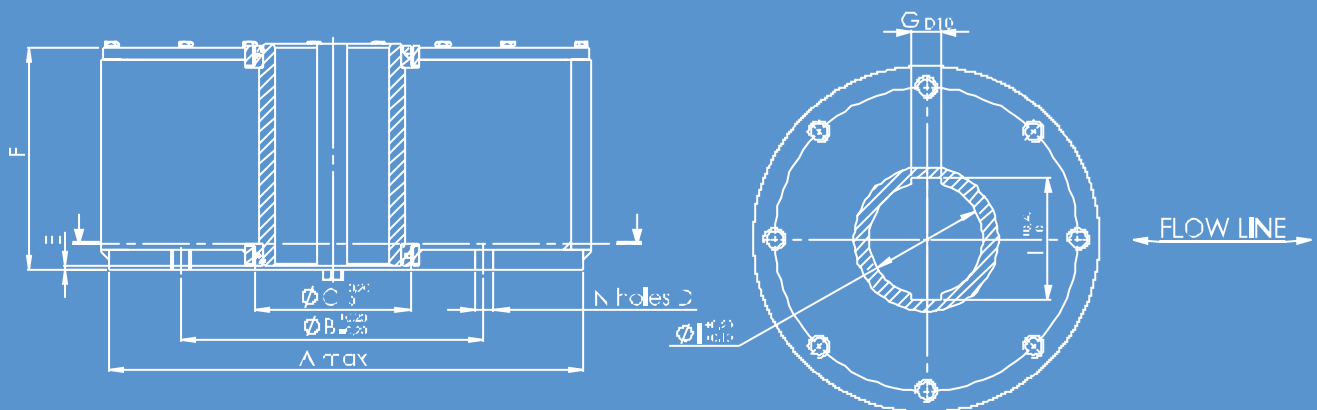

Model Size	A	B	C	D	E	F	G	H	I
120	560	483	250	N.12 M36	5	394	45	195.8	175
180	680	603	285	N.20 M36	5	418	45	220.8	200